

***The 16th edition of ICVL 2021 - International Conference on
Virtual Learning***

20.11.2021



Remote Laboratory for Renewable Energy Courses

**Radu Tîrcă¹, Luca Mihăilescu¹, Eleonora Popescu¹,
Daniel Costache¹, Victor-Tiberiu Dumitru², Sanda
Voinea¹**

1) University of Bucharest, Faculty of Physics, 405
Atomiștilor Street, 077125, Măgurele, Romania

2) University of Bucharest, Faculty of Mathematics and
Computer Science, 14 Academiei Street, 010014,
Bucharest, Romania



Introduction

The aim of this article is to show ways through which we can turn a classic electrolysis experiment, as a source of hydrogen production, into a completely remote laboratory.



Brief Theoretical Considerations

The basis of the electrolysis experiment is the reduction-oxidation process happening when direct current passes through an electrolyte mixture (solution or melt that decomposes under the influence of an electric current).



The classic experimental setup revolves around two electrodes connected to a power supply, submerged in an electrolyte solution.

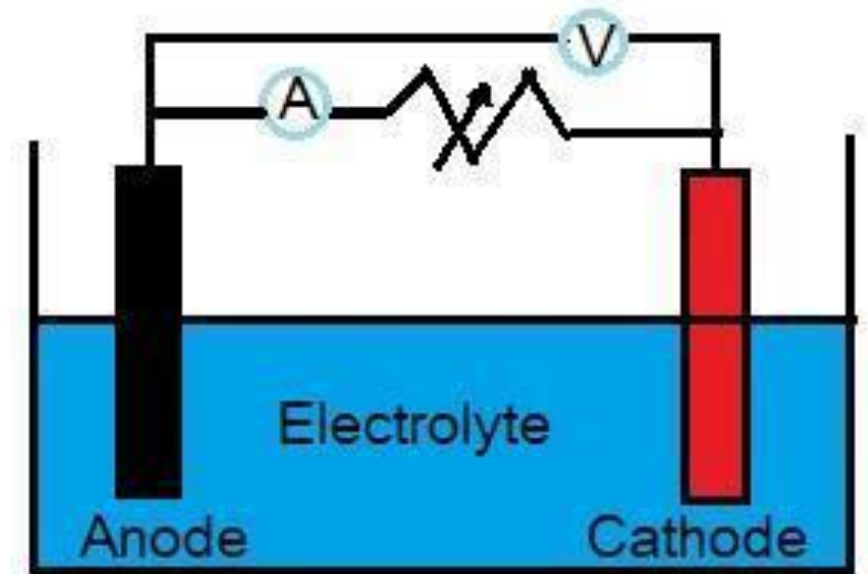



The main applications of electrolysis include:

- Electrochemical engineering
 - Renewable energy
 - Bioelectrochemistry
- Environmental protection
 - Biomedicine



Experimental Setup



(Not to scale)

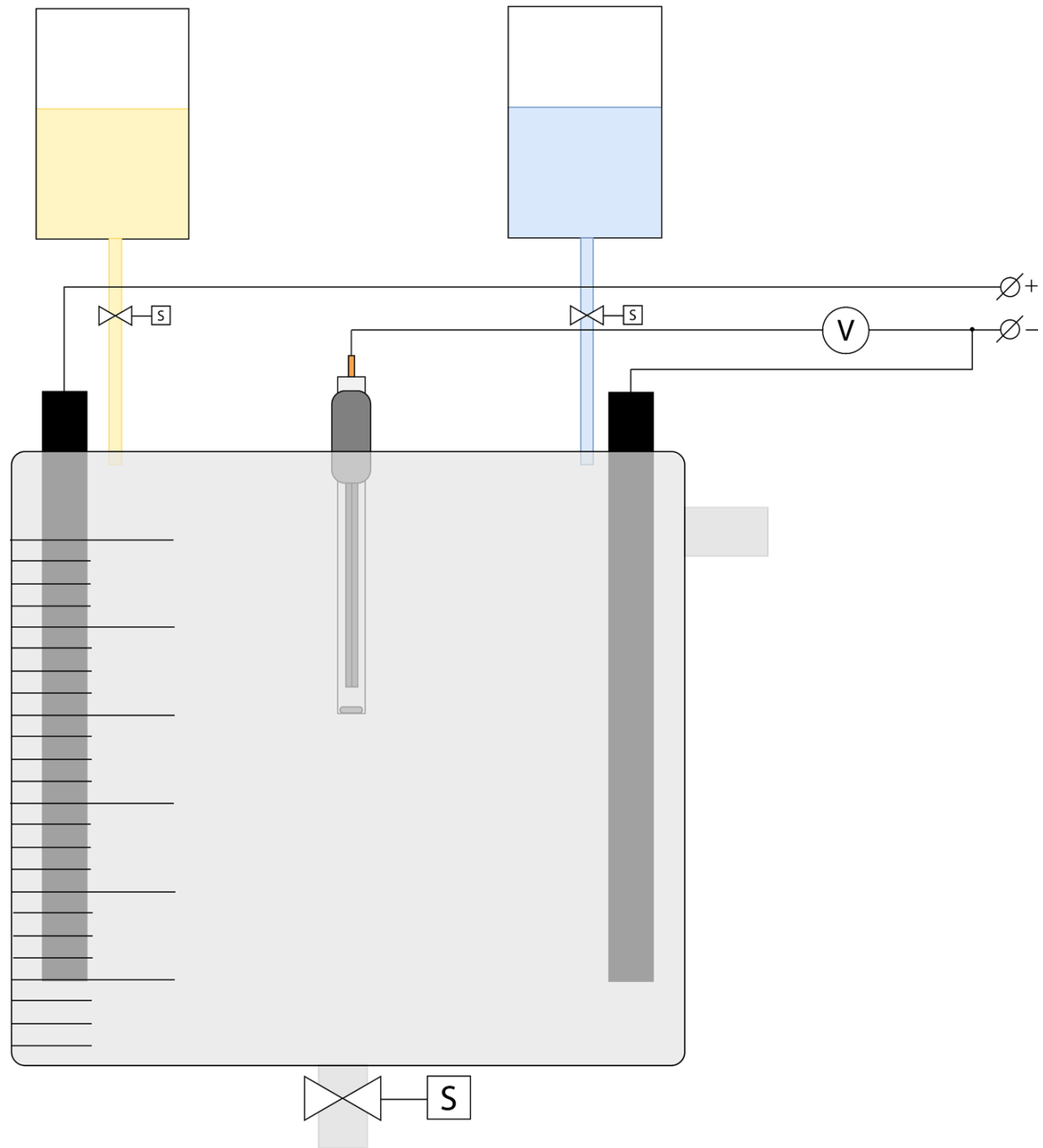

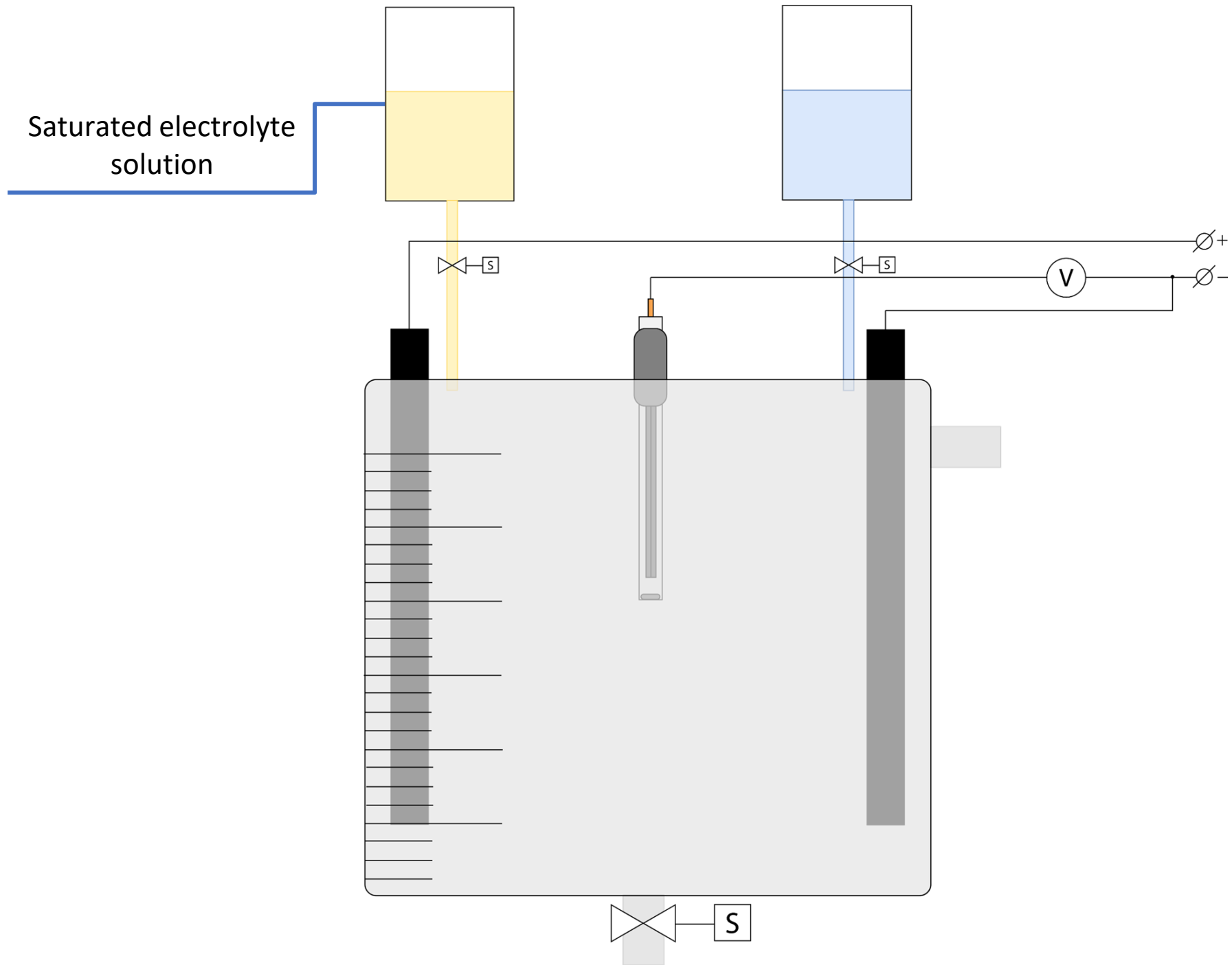

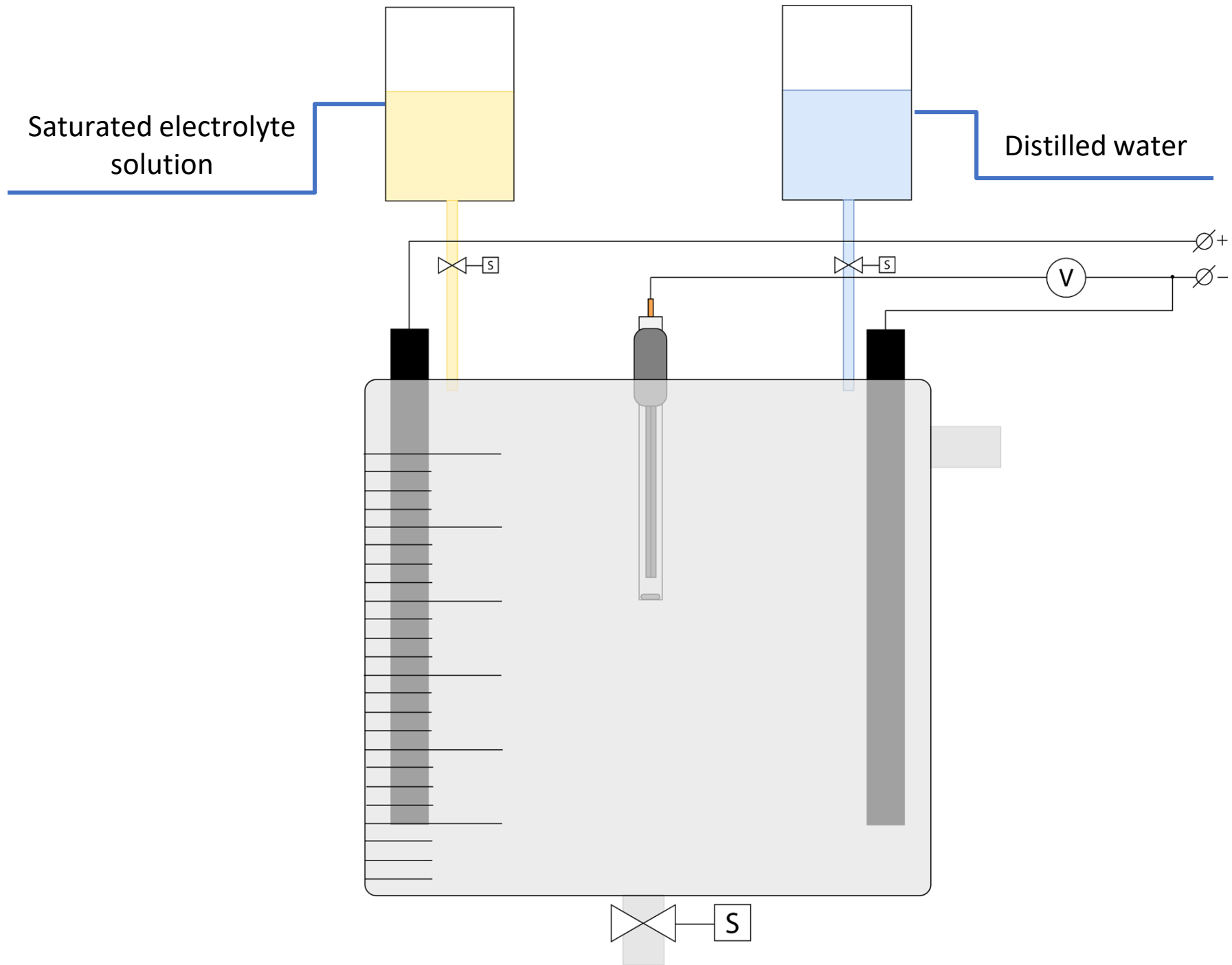

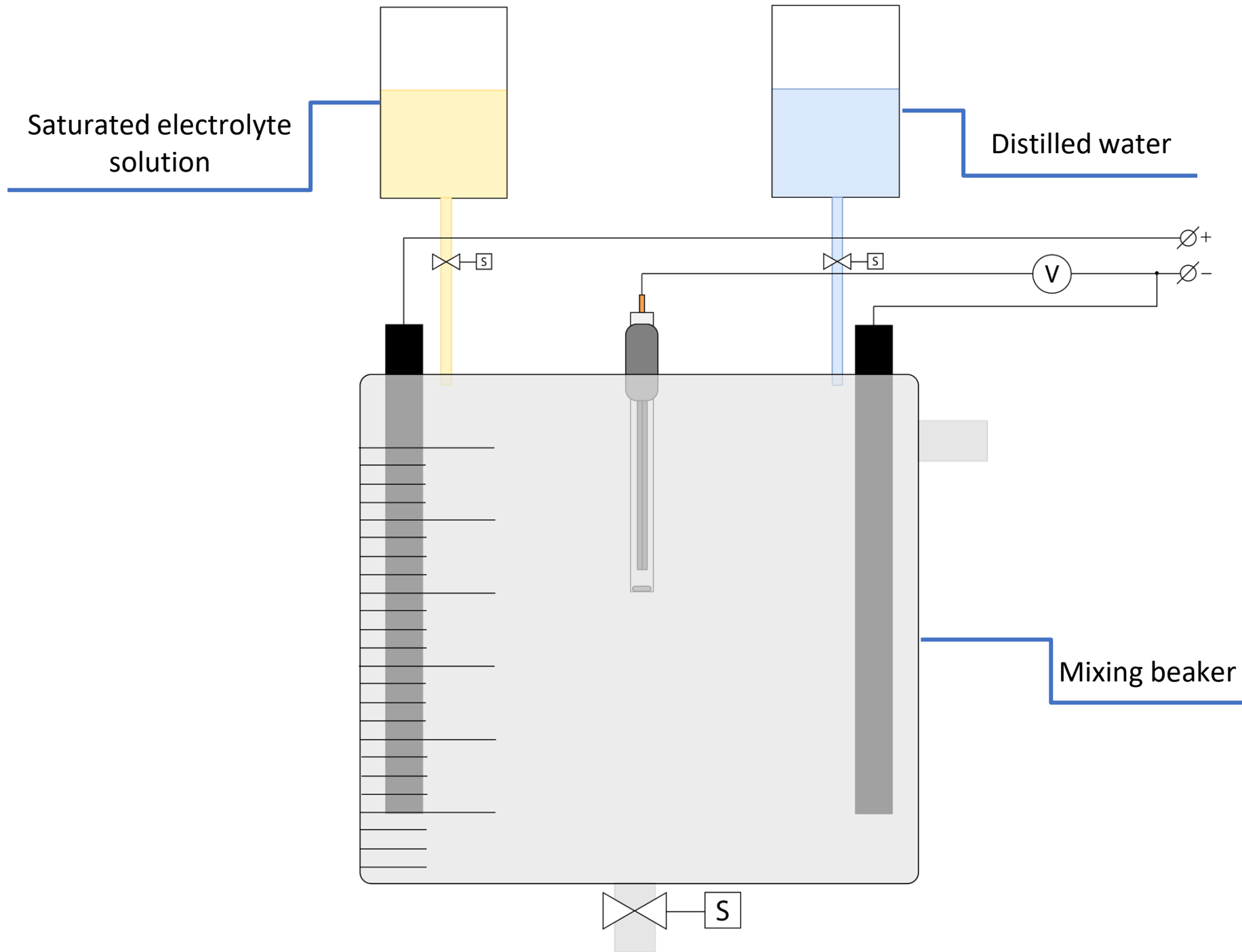

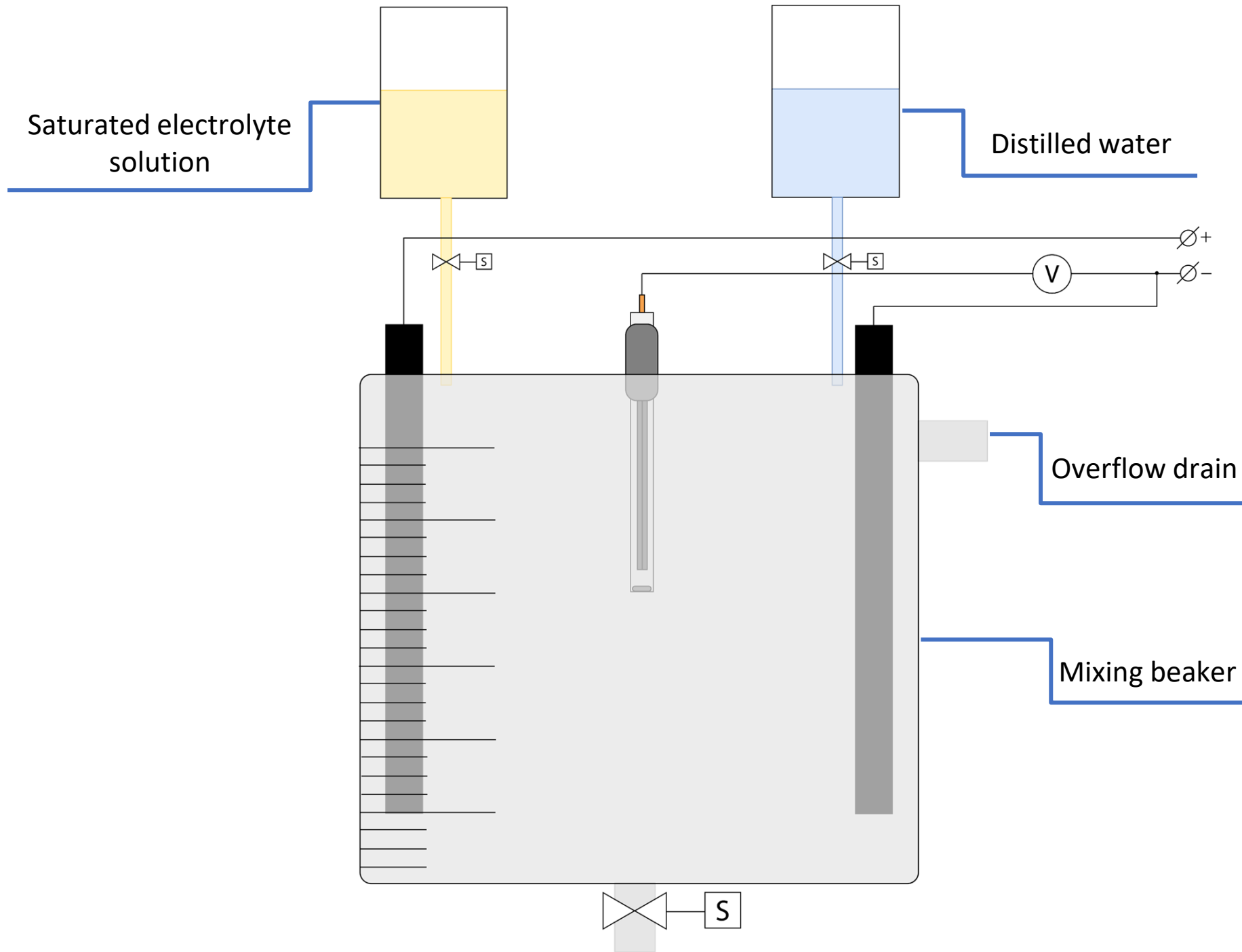

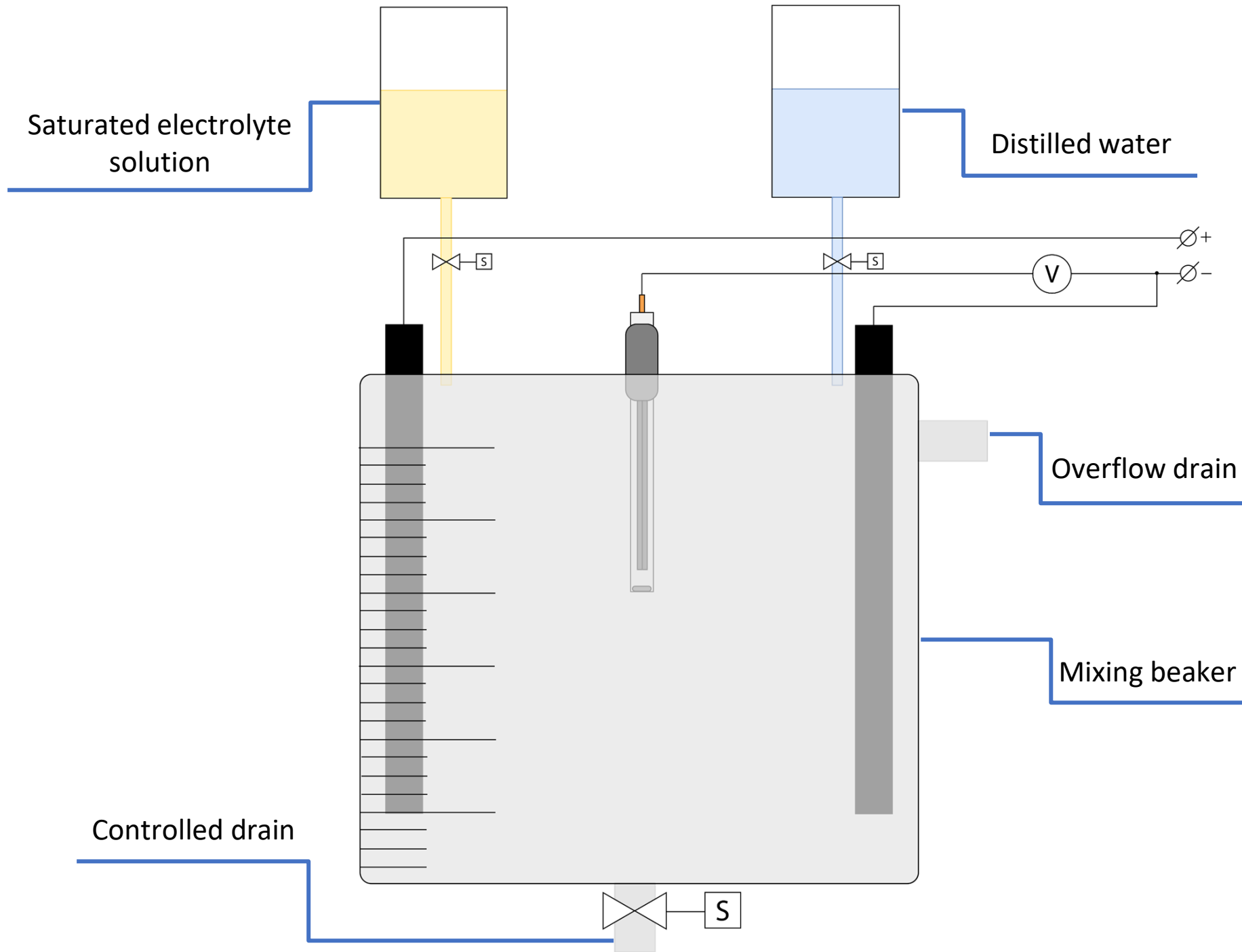

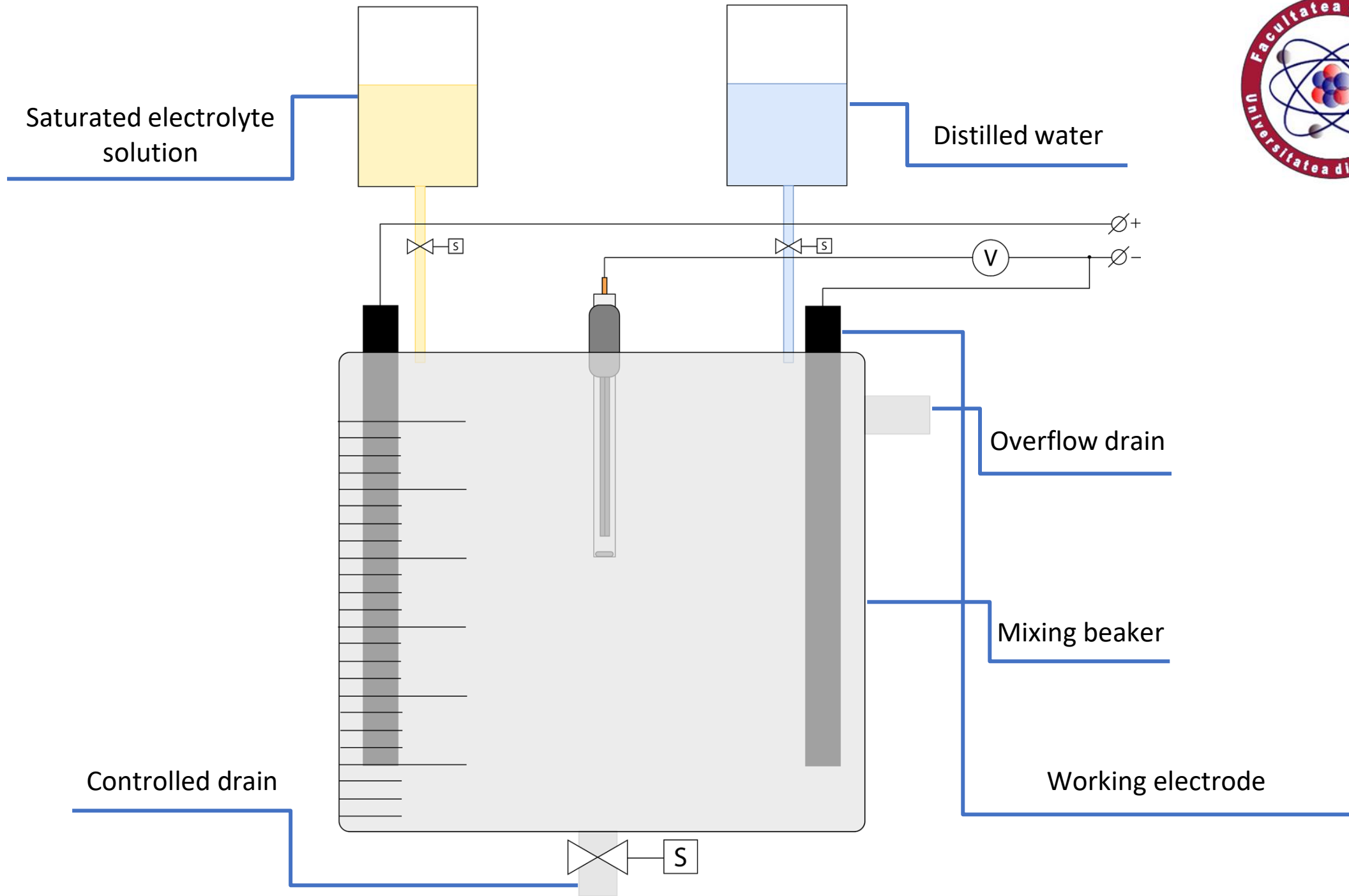

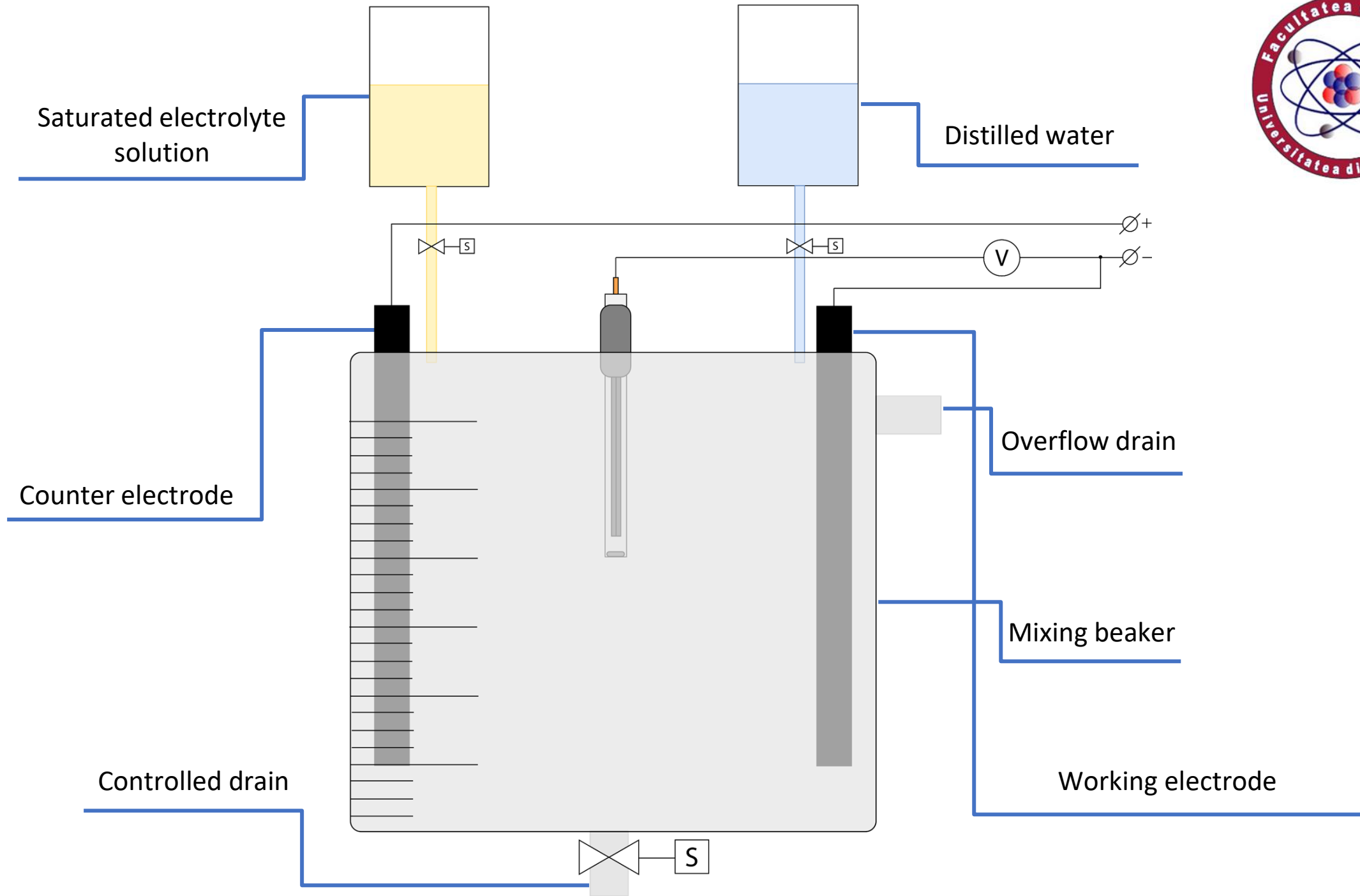

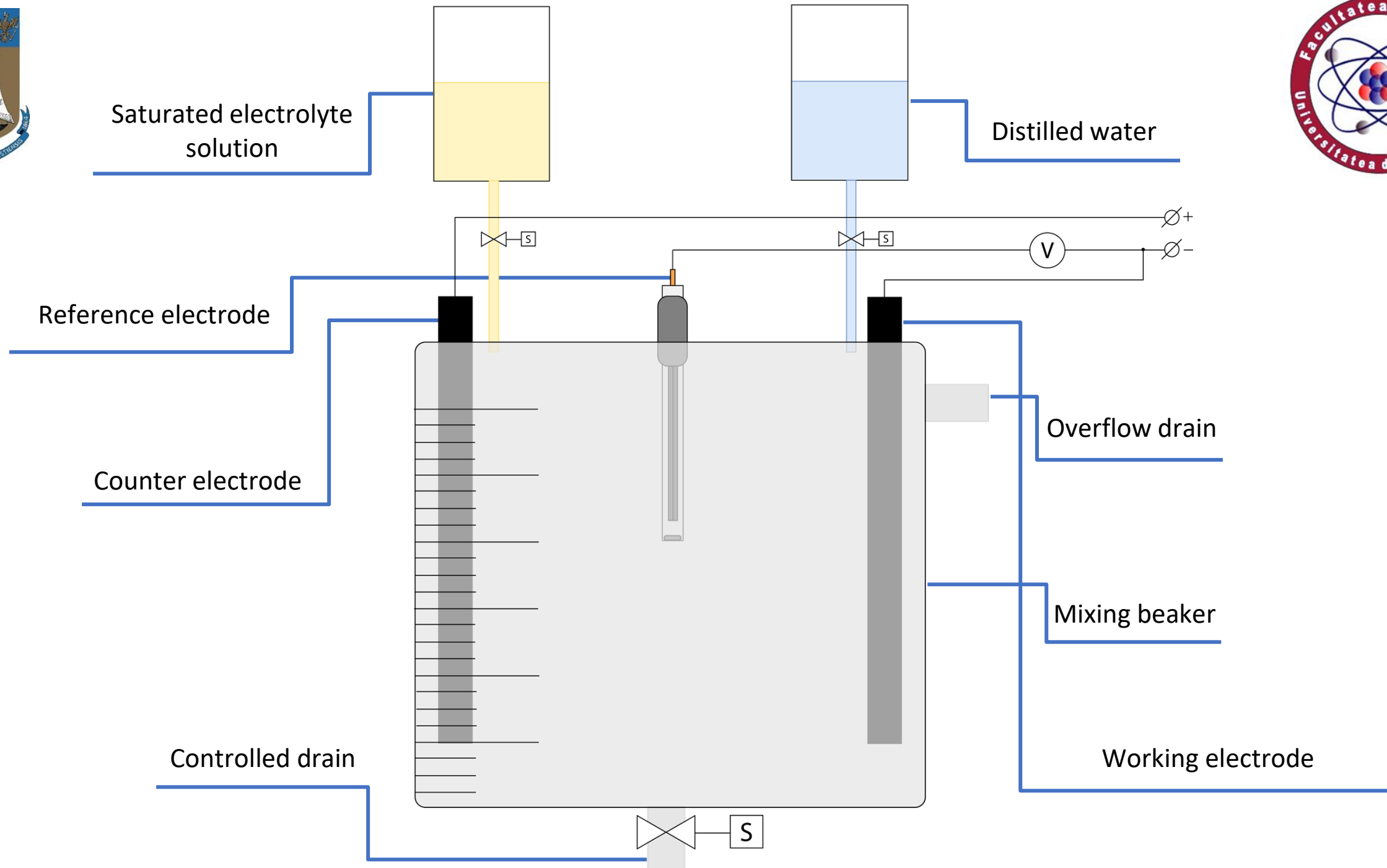

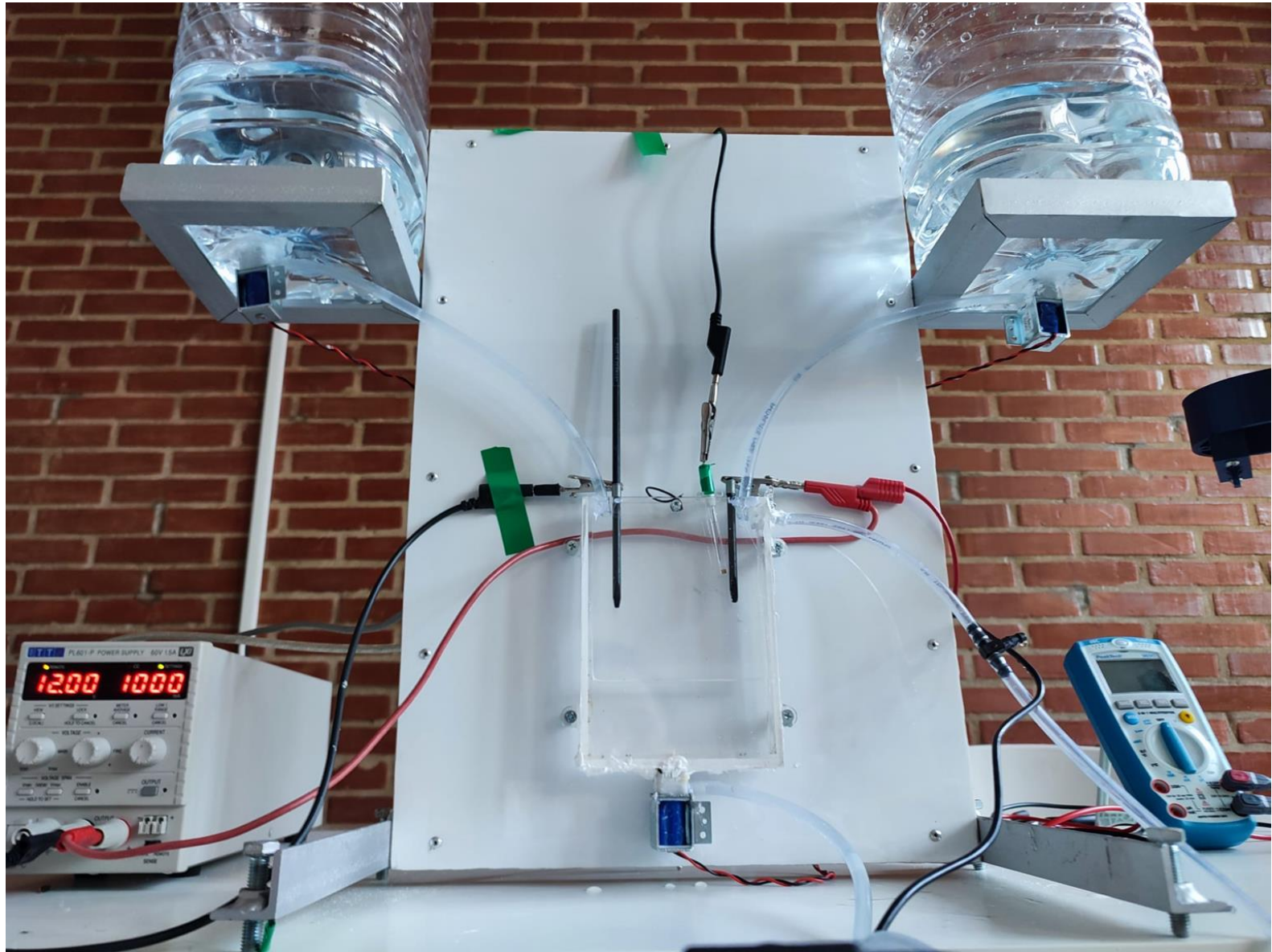



Making the Experiment Remote

In order to enable the experiment to be fully operated remotely, a SCARA (Selective Compliance Articulated Robot Arm) was used. The robot is managed by an Arduino microcontroller which drives the motors that put the robot in motion.

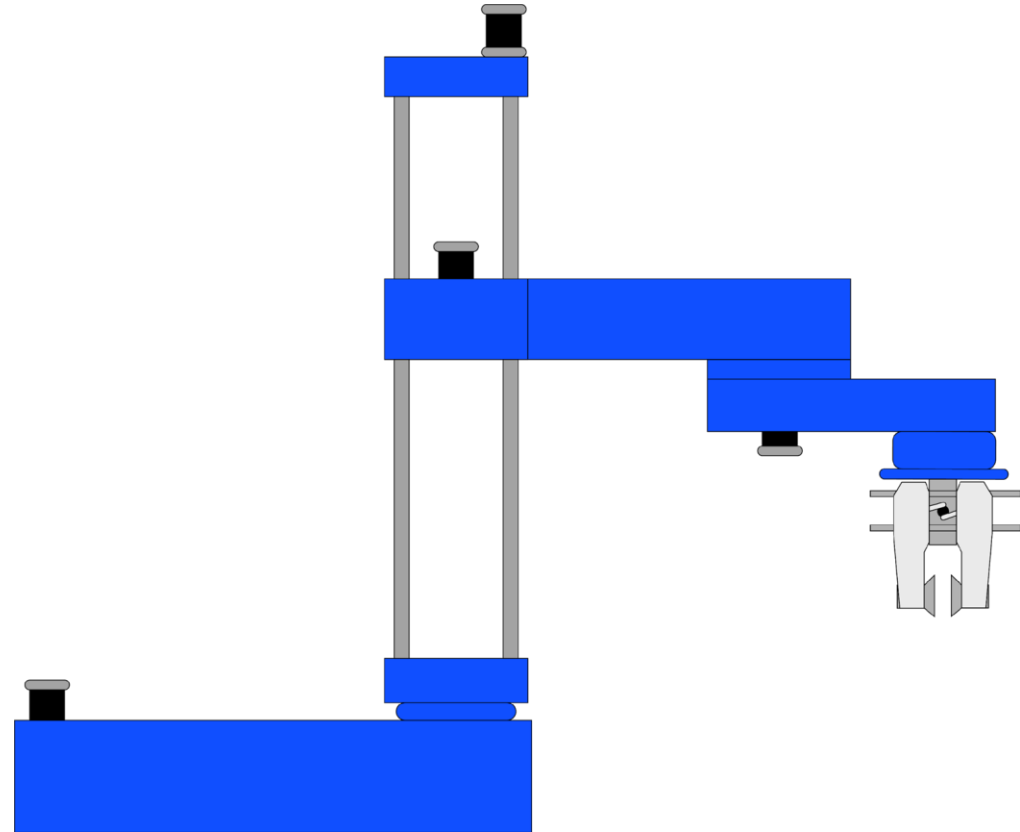



Advantages of the Robotic Arm

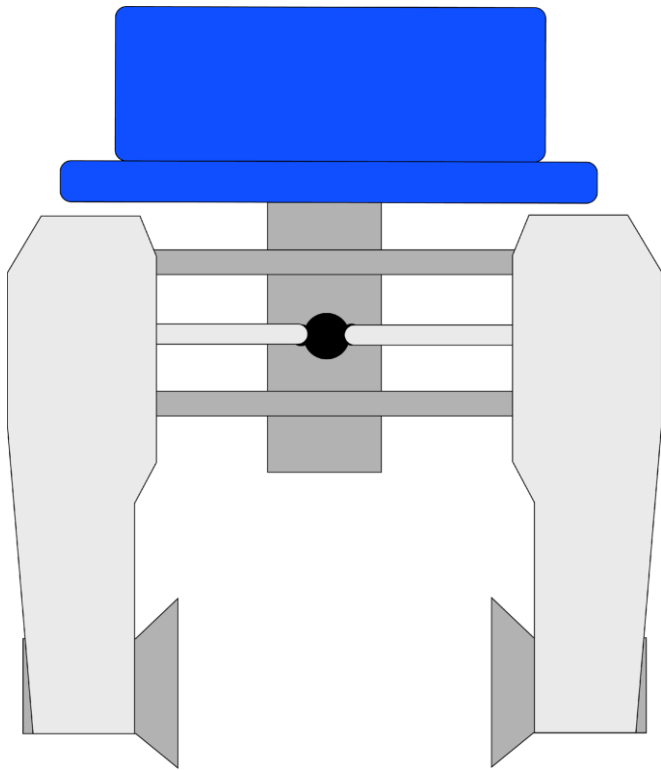

The SCARA is fitted with a gripper end controlled by a servomotor, which allows for fine adjustments in the grip width of the claw. In this case, the gripper end will hold the reference electrode and move it inside of the beaker, so that different voltages can be measured.

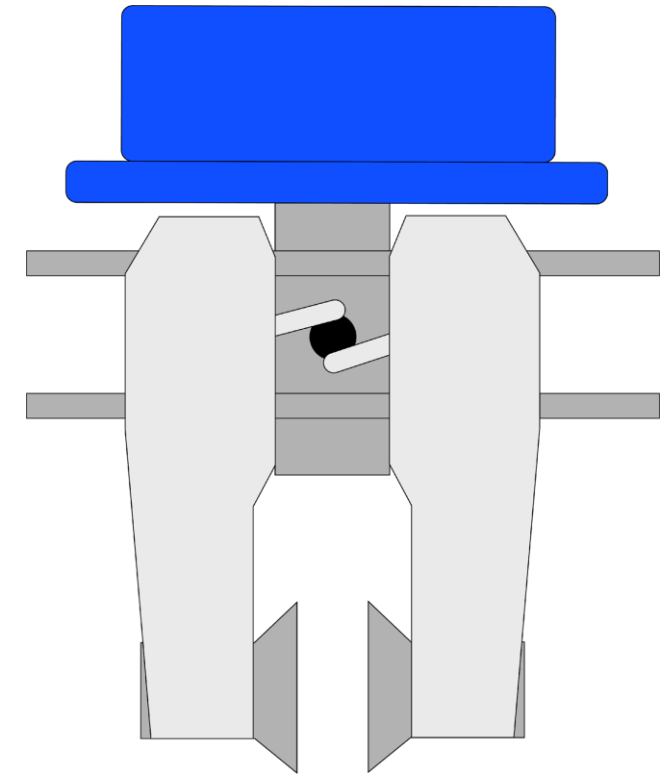



Accessing the Remote Laboratory

The experimental setup will be controlled remotely via a web interface, which will provide the ability to control almost all of the actions needed to complete the experiment. The interface will grant the user a video feed of the setup, and will allow them to maneuver the robot by inputting different motion parameters.





The server behind the web interface is hosted on a Raspberry Pi, which communicates with the Arduino of the SCARA and also operates the solenoid valves and the programmable power supply used to apply tension between the working and the counter electrode.



Experimental Procedure



 Welcome	 Remote lab
 Remote lab	Concentration (%) 50
	Time (seconds) 5
	Voltage (Volts) 8
	Update interval (seconds) 1

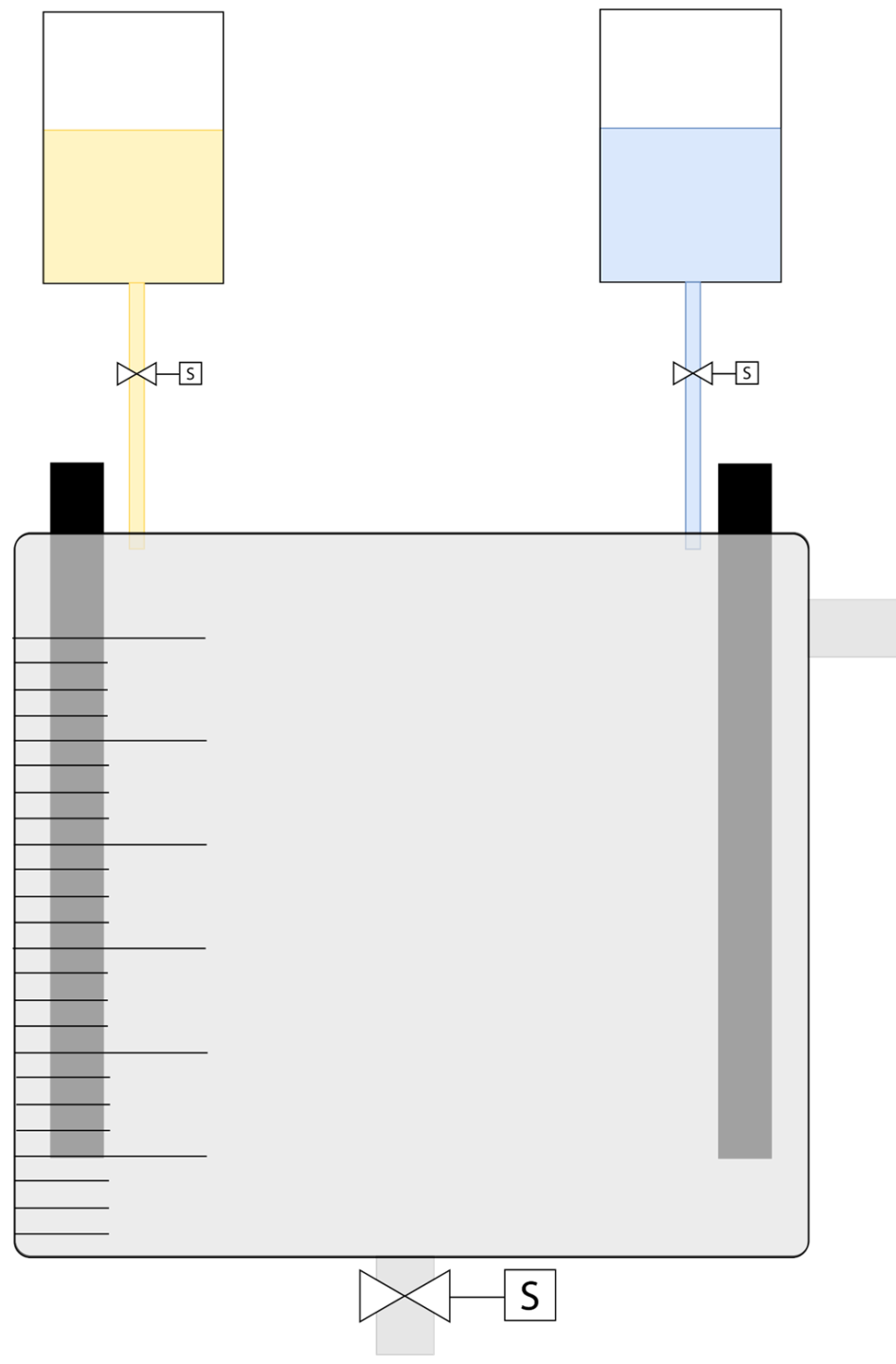

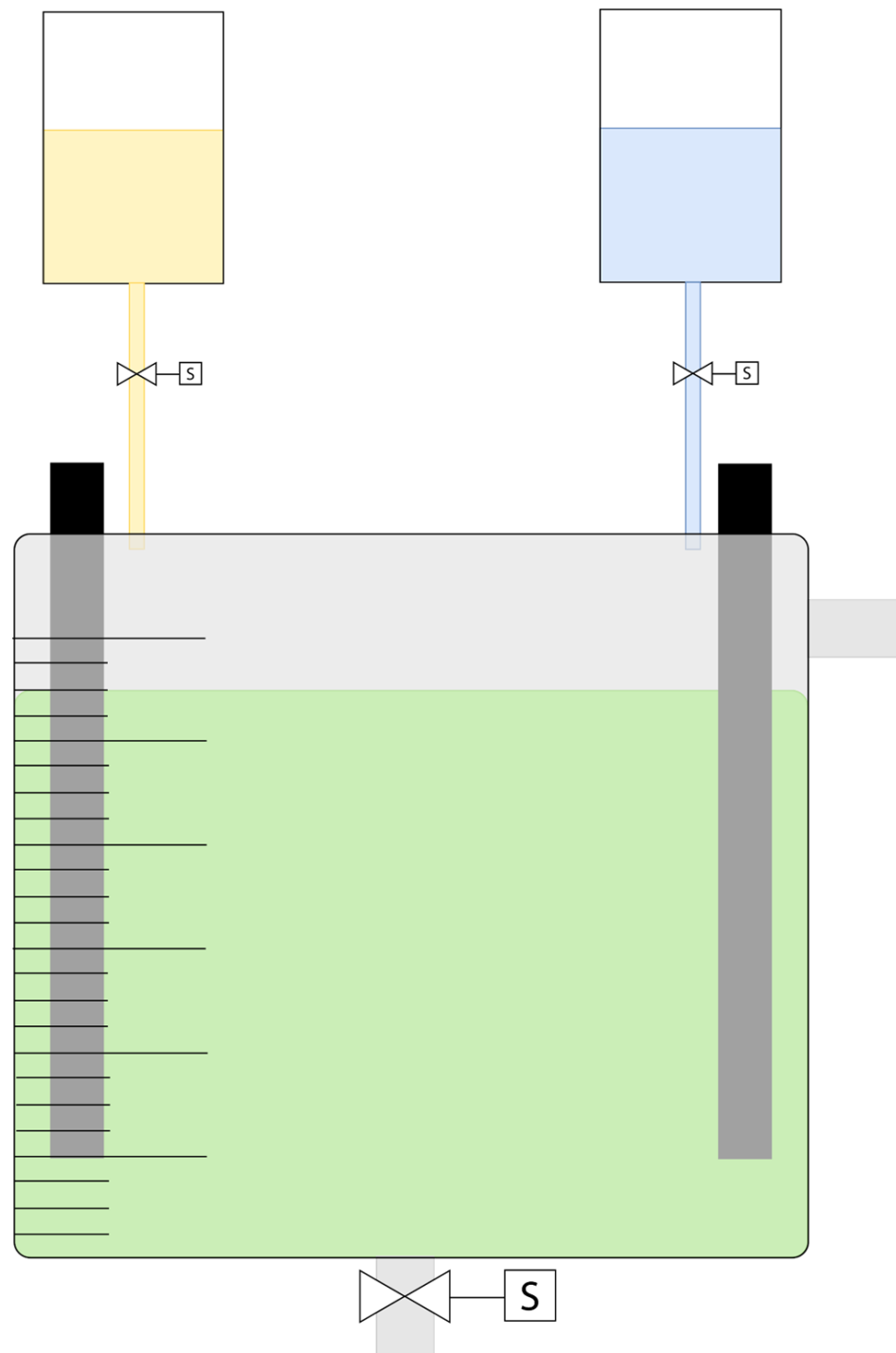

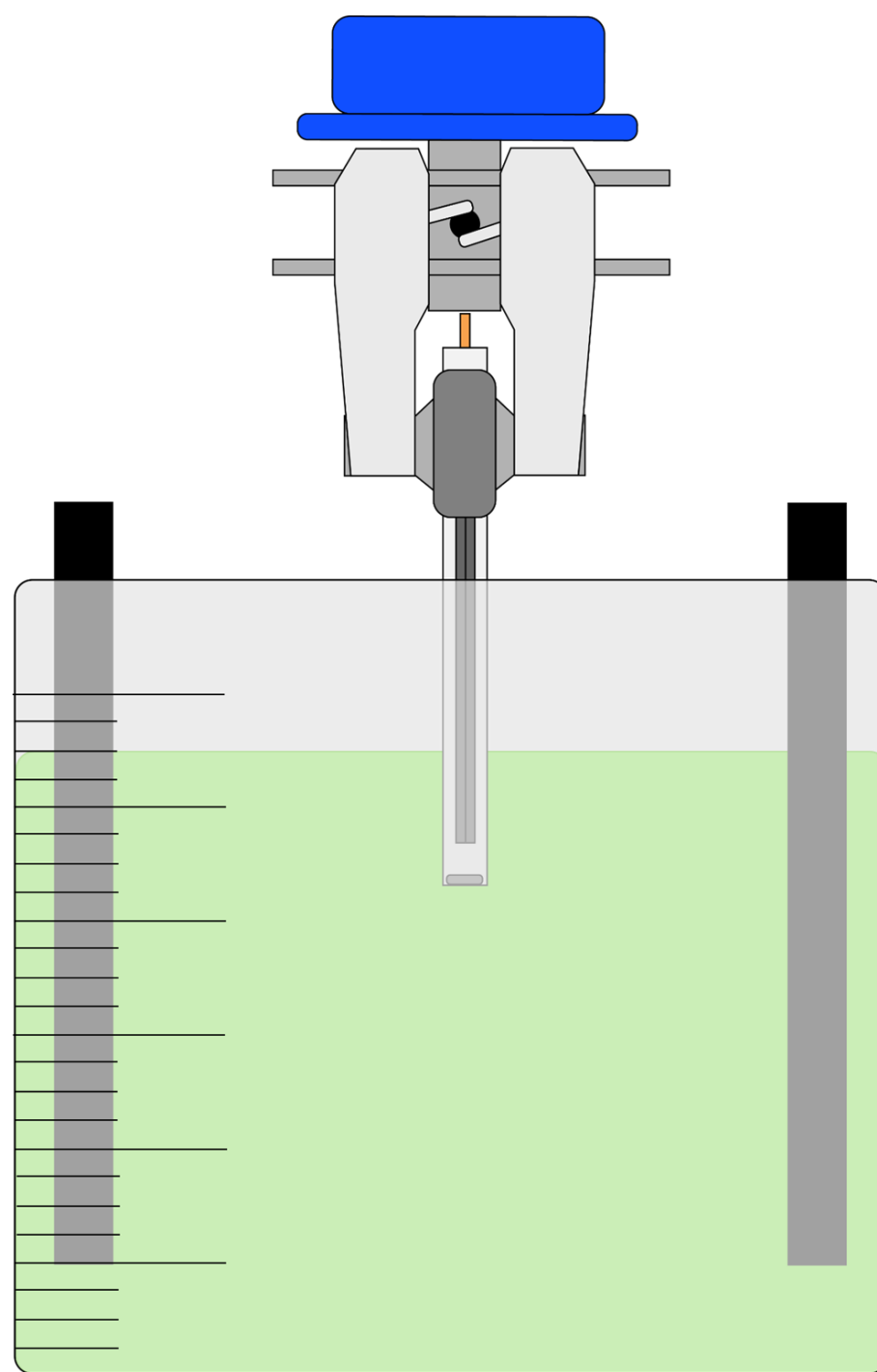

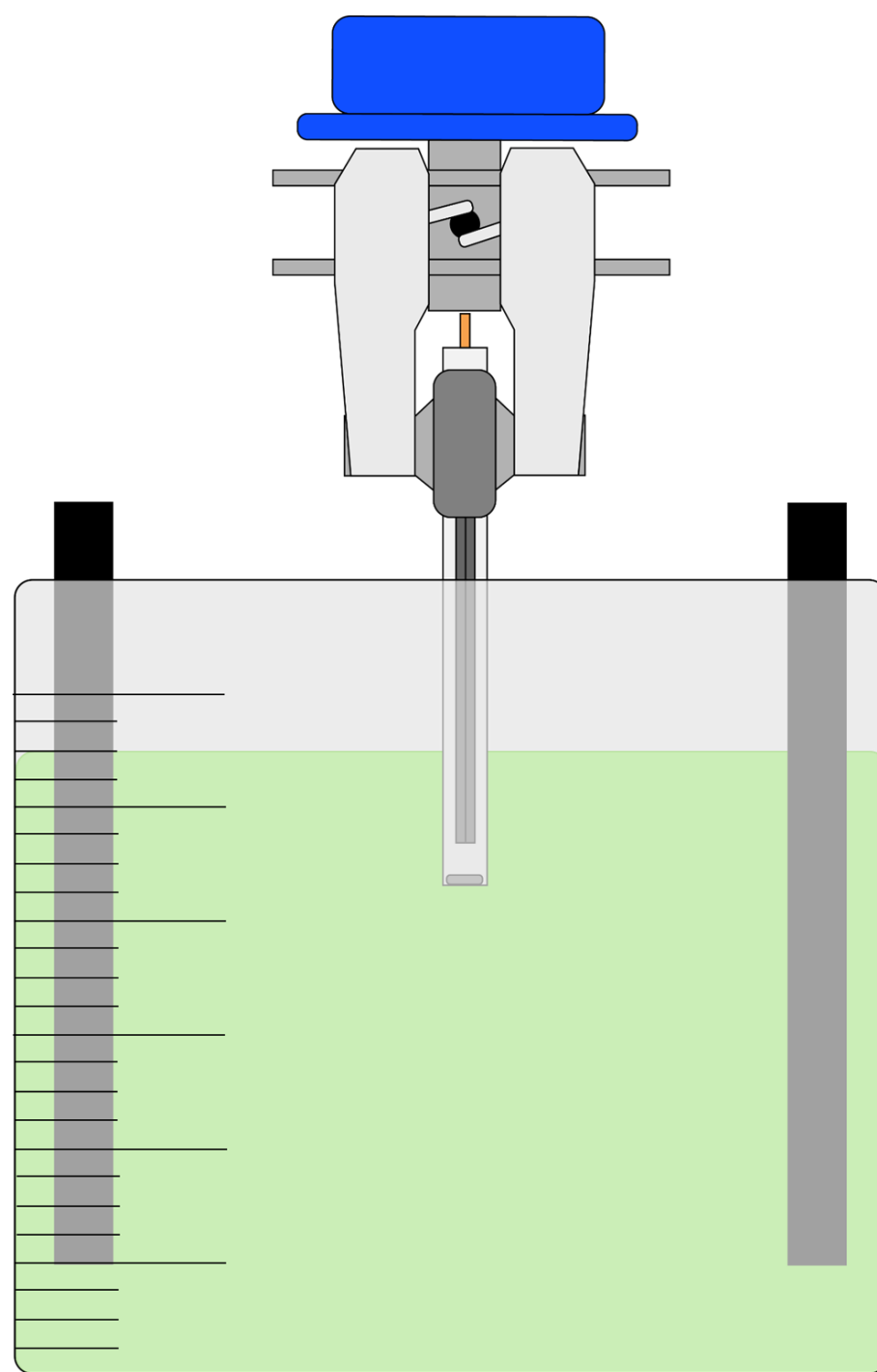

V - Applied tension

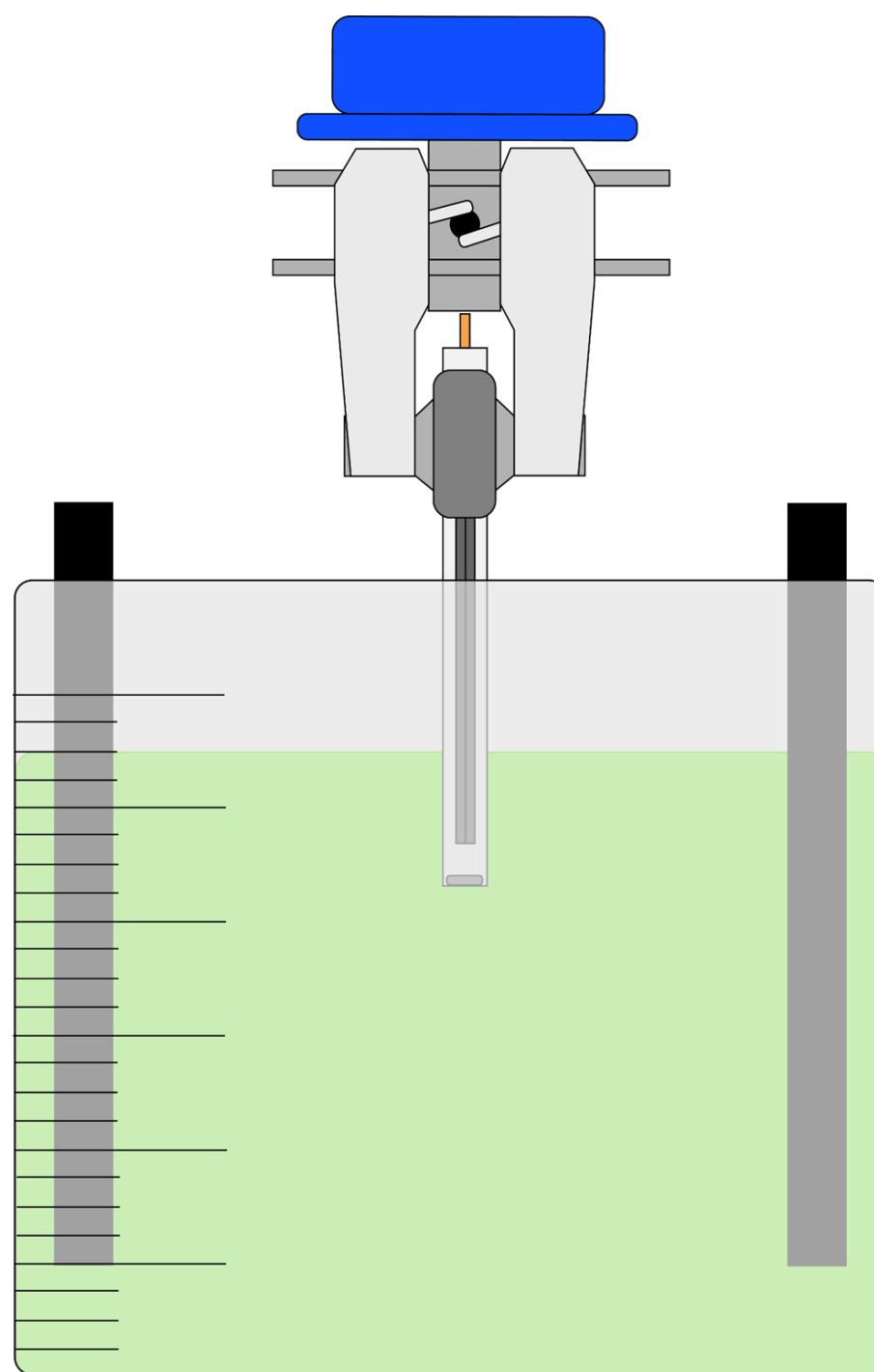

V - Applied tension

I - Applied current

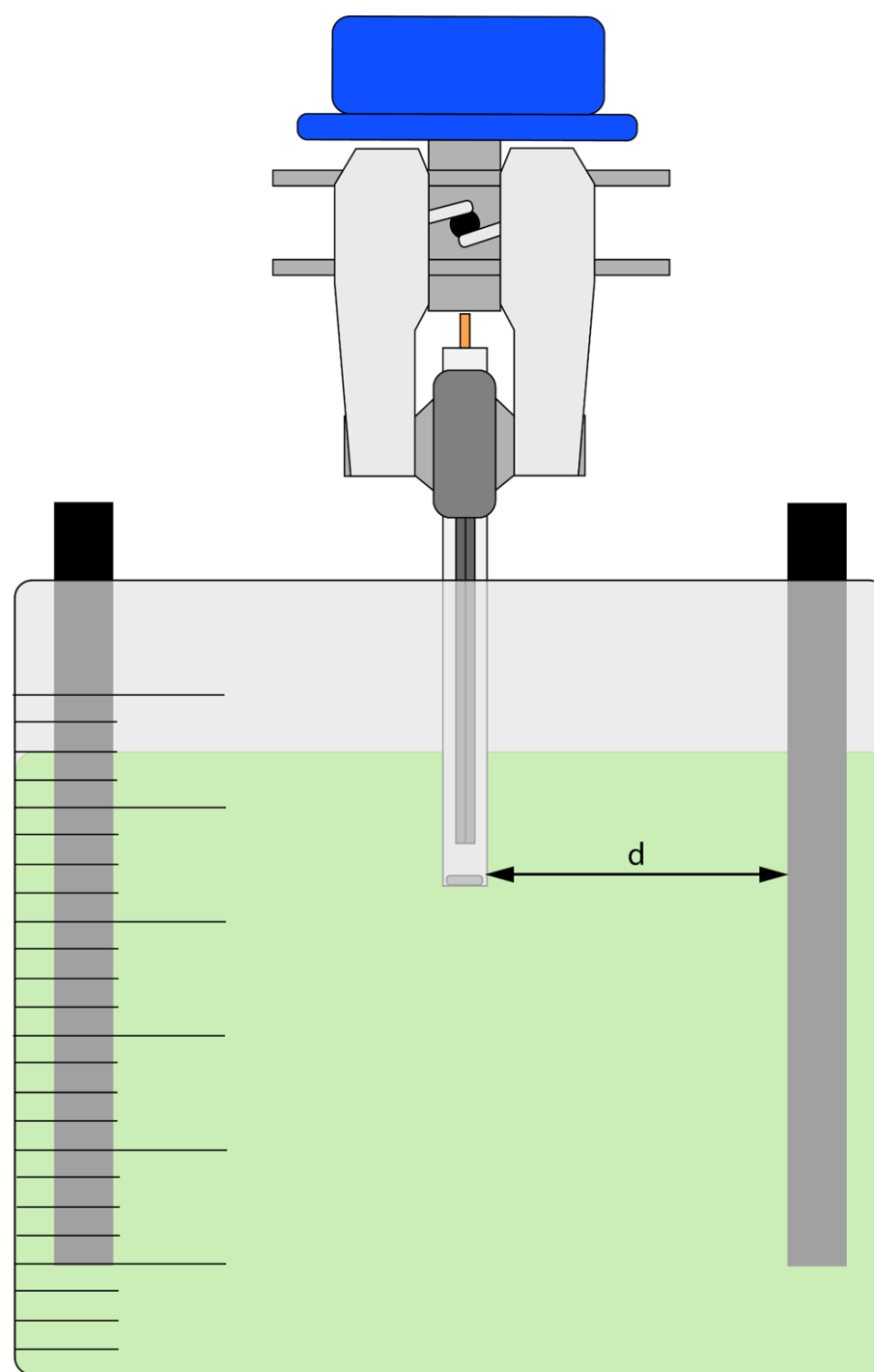

V - Applied tension

I - Applied current

V_m - Tension measured by the voltmeter

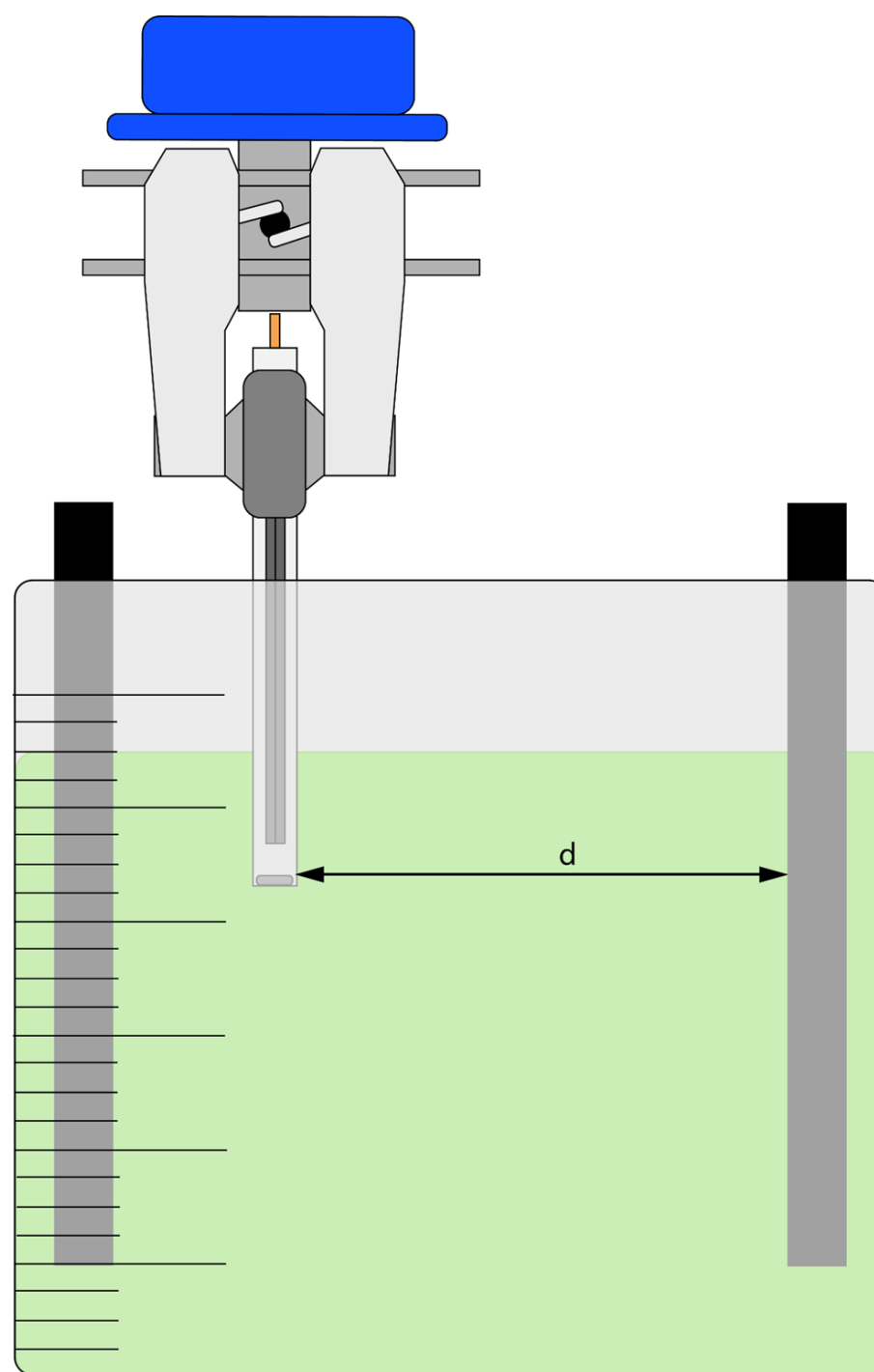

V - Applied tension

I - Applied current

V_m - Tension measured by the voltmeter

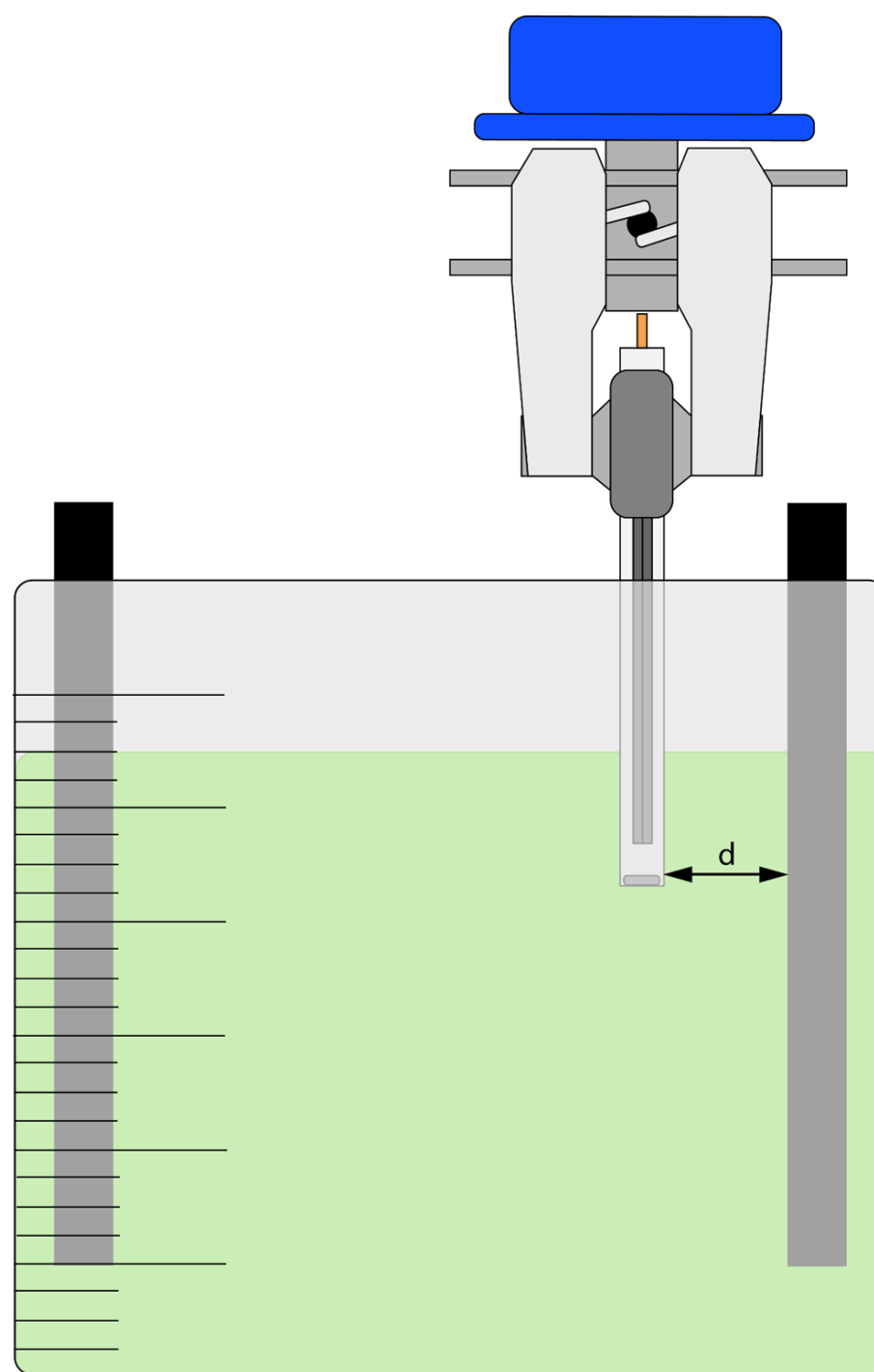

V - Applied tension

I - Applied current

V_m - Tension measured by the voltmeter



Data Acquisition

The data measurements are done using the power supply, which has been programmed to return the value of the measured tension back to the user of the interface. Then, they can download the data in table format.

Also, a video camera was fitted, providing live video feed of the experiment.



Making Connections and Future Plans

Up to this moment, a laboratory session was already held, having promising results and positive feedback from the operators of the setup.

Our project is part of the ITRES Program, a joint effort held with students from the Iceland School of Energy, Reykjavik University, regarding methods of renewable energy.



Our future goal for this project is to further improve our experimental setup and, due to the versatility of the web server and SCARA, expand into other fields of study.



Conclusion

The robotic setup presented is suitable for emulating proper laboratory conditions and allowing students from all around the world to remotely operate the experiment and observe the physical phenomena taking place during water electrolysis.



Acknowledgements

Iceland 
Liechtenstein
Norway grants

“Working together for a green, competitive and inclusive Europe”

This work was supported by a grant from the EEA Financial Mechanism 2014-2021, Projects of cooperation in university education” Education, Scholarships, Apprenticeship and Youth Entrepreneurship Program in Romania”, the project number 19-COP-0025,” *Innovative Teaching methods for tomorrow’s Renewable Energy Specialists*” (<http://itres.unibuc.ro/>).

The project is a cooperation between the Faculty of Physics at the University of Bucharest and the Iceland School of Energy at Reykjavik University.

Its content does not reflect the official opinion of the Program Operator, the National Contact Point or the Office of the Financial Mechanism. The information and opinions expressed are the sole responsibility of the authors.